

CX290D
Crawler Excavator

SERVICE MANUAL

Part number 48155069

English

February 2018

© 2018 CNH Industrial Italia S.p.A. All Rights Reserved.

CASE
CONSTRUCTION



SERVICE MANUAL

CX290D Crawler excavators LC Material Handling (TIER4 FINAL) - EU Market
CX290D Crawler excavators LC Scrap Loader (TIER4 FINAL) - EU Market

Contents

INTRODUCTION

Engine.....	10
[10.001] Engine and crankcase	10.1
[10.102] Pan and covers	10.2
[10.106] Valve drive and gears	10.3
[10.101] Cylinder heads	10.4
[10.105] Connecting rods and pistons.....	10.5
[10.103] Crankshaft and flywheel.....	10.6
[10.216] Fuel tanks	10.7
[10.206] Fuel filters	10.8
[10.218] Fuel injection system.....	10.9
[10.202] Air cleaners and lines	10.10
[10.250] Turbocharger and lines.....	10.11
[10.254] Intake and exhaust manifolds and muffler	10.12
[10.500] Selective Catalytic Reduction (SCR) exhaust treatment.....	10.13
[10.501] Exhaust Gas Recirculation (EGR) exhaust treatment.....	10.14
[10.400] Engine cooling system	10.15
[10.414] Fan and drive	10.16
[10.310] Aftercooler.....	10.17
[10.304] Engine lubrication system.....	10.18
Hydraulic systems.....	35
[35.000] Hydraulic systems.....	35.1
[35.300] Reservoir, cooler, and filters.....	35.2
[35.106] Variable displacement pump	35.3
[35.102] Pump control valves.....	35.4
[35.359] Main control valve.....	35.5
[35.357] Pilot system	35.6

[35.355] Hydraulic hand control	35.7
[35.356] Hydraulic foot control.....	35.8
[35.352] Hydraulic swing system	35.9
[35.353] Hydraulic travel system	35.10
[35.354] Hydraulic central joint	35.11
[35.736] Boom hydraulic system	35.12
[35.737] Dipper hydraulic system.....	35.13
[35.738] Excavator and backhoe bucket hydraulic system.....	35.14
[35.360] Hammer and rotating bucket hydraulic system	35.15
[35.100] Main lift system.....	35.16
Frames and ballasting	39
[39.140] Ballasts and supports	39.1
Tracks and track suspension.....	48
[48.130] Track frame and driving wheels	48.1
[48.100] Tracks	48.2
[48.134] Track tension units	48.3
[48.138] Track rollers	48.4
Cab climate control	50
[50.100] Heating	50.1
[50.200] Air conditioning.....	50.2
Electrical systems	55
[55.000] Electrical system	55.1
[55.100] Harnesses and connectors.....	55.2
[55.525] Cab engine controls.....	55.3
[55.015] Engine control system.....	55.4
[55.201] Engine starting system	55.5
[55.301] Alternator.....	55.6
[55.302] Battery.....	55.7

**Thanks very much for your reading,
Want to get more information,
Please click here, Then get the complete
manual**

JustClickHere 

NOTE:

**If there is no response to click on the link above,
please download the PDF document first, and then
click on it.**

**Have any questions please write to me:
admin@servicemanualperfect.com**

[55.202] Cold start aid	55.8
[55.011] Fuel tank system	55.9
[55.010] Fuel injection system	55.10
[55.014] Engine intake and exhaust system	55.11
[55.988] Selective Catalytic Reduction (SCR) electrical system	55.12
[55.989] Exhaust Gas Recirculation (EGR) electrical system	55.13
[55.012] Engine cooling system	55.14
[55.013] Engine oil system	55.15
[55.640] Electronic modules	55.16
[55.512] Cab controls	55.17
[55.036] Hydraulic system control	55.18
[55.051] Cab Heating, Ventilation, and Air-Conditioning (HVAC) controls	55.19
[55.050] Heating, Ventilation, and Air-Conditioning (HVAC) control system	55.20
[55.524] Cab controls (Lift arm, Boom, Dipper, Bucket)	55.21
[55.416] Swing control system	55.22
[55.417] Travel control system	55.23
[55.530] Camera	55.24
[55.518] Wiper and washer system	55.25
[55.054] Cab interference prevention system	55.26
[55.404] External lighting	55.27
[55.514] Cab lighting	55.28
[55.408] Warning indicators, alarms, and instruments	55.29
[55.992] Anti-theft system	55.30
[55.DTC] FAULT CODES	55.31
Booms, dippers, and buckets	84
[84.910] Boom	84.1
[84.912] Dipper arm	84.2
[84.100] Bucket	84.3

Platform, cab, bodywork, and decals	90
[90.150] Cab	90.1
[90.154] Cab doors and hatches	90.2
[90.156] Cab windshield and windows	90.3
[90.118] Protections and footboards.....	90.4
[90.120] Mechanically-adjusted operator seat.....	90.5
[90.100] Engine hood and panels	90.6



INTRODUCTION

Contents

INTRODUCTION

Foreword - Important notice regarding equipment servicing	3
Safety rules	4
Safety rules - General information	5
Safety rules - Personal safety	6
Safety rules - Ecology and the environment	8
Torque - Bolt and nut	9
Torque - Special torque setting (*)	10
Torque - Special torque setting (*)	14
Basic instructions - Shop and assembly	18
General specification (*)	20
General specification (*)	24
General specification - Main equipment (*)	28
General specification - Main equipment (*)	35
Weight (*)	42
Weight (*)	44
Dimension (*)	46
Dimension (*)	47
Consumables	48
Conversion factors	51
Abbreviation	63
Product identification	66
Product identification - Machine orientation	69

(*) See content for specific models

Foreword - Important notice regarding equipment servicing

All repair and maintenance work listed in this manual must be carried out only by qualified dealership personnel, strictly complying with the instructions given, and using, whenever possible, the special tools.

Anyone who performs repair and maintenance operations without complying with the procedures provided herein shall be responsible for any subsequent damages.

The manufacturer and all the organizations of its distribution chain, including - without limitation - national, regional, or local dealers, reject any responsibility for damages caused by parts and/or components not approved by the manufacturer, including those used for the servicing or repair of the product manufactured or marketed by the manufacturer. In any case, no warranty is given or attributed on the product manufactured or marketed by the manufacturer in case of damages caused by parts and/or components not approved by the manufacturer.

The manufacturer reserves the right to make improvements in design and changes in specifications at any time without notice and without incurring any obligation to install them on units previously sold. Specifications, descriptions, and illustrative material herein are as accurate as known at time of publication but are subject to change without notice.

In case of questions, refer to your CASE CONSTRUCTION Sales and Service Networks.

Safety rules

Personal safety





This is the safety alert symbol. It is used to alert you to potential personal injury hazards. Obey all safety messages that follow this symbol to avoid possible death or injury.

Throughout this manual you will find the signal words DANGER, WARNING, and CAUTION followed by special instructions. These precautions are intended for the personal safety of you and those working with you.

Read and understand all the safety messages in this manual before you operate or service the machine.

 DANGER indicates a hazardous situation that, if not avoided, will result in death or serious injury.

 WARNING indicates a hazardous situation that, if not avoided, could result in death or serious injury.

 CAUTION indicates a hazardous situation that, if not avoided, could result in minor or moderate injury.

FAILURE TO FOLLOW DANGER, WARNING, AND CAUTION MESSAGES COULD RESULT IN DEATH OR SERIOUS INJURY.

Machine safety

NOTICE: Notice indicates a situation that, if not avoided, could result in machine or property damage.

Throughout this manual you will find the signal word Notice followed by special instructions to prevent machine or property damage. The word Notice is used to address practices not related to personal safety.

Information

NOTE: Note indicates additional information that clarifies steps, procedures, or other information in this manual.

Throughout this manual you will find the word Note followed by additional information about a step, procedure, or other information in the manual. The word Note is not intended to address personal safety or property damage.

Safety rules - General information

Cleaning

Clean the metal parts with cleaning solution that meets the standard and steam cleaning. (except for bearings)

After cleaning, dry well, and inject oil in all parts.

Also inject oil into the bearings after drying.

Inspection

When disassembling parts, check all the parts.

If there are any worn or damaged parts, replace them.

Inspect carefully to prevent initial breakdowns.

Bearing

Replace any loose bearings.

Air dry bearings before installing them.

Needle bearing

When inserting needle bearings, be very careful not to damage them.

Apply grease to the section where the needle bearing will be inserted.

Gear

Check that there is no wear and no damage.

Oil seal, O-ring, gasket

Always install new oil seals, O-rings, and gaskets.

Apply grease to sections where oil seals and O-rings will be inserted.

Shaft

Check that there is no wear and no damage.

Check the bearings and check for damaged oil seals on the shaft.

Service parts

Install CASE CONSTRUCTION genuine service parts.

When placing an order, check the parts catalog. It contains the CASE CONSTRUCTION genuine part numbers.

Any breakdowns arising from the installation of non-genuine parts are not covered by the warranty.

Lubricants (fuel, hydraulic oil)

Use the oil from the specified company or specified in the operator's manual or service Manual.

Any breakdowns arising from any fuel or hydraulic oil other than those specified are not covered by the warranty.

Safety rules - Personal safety

 **WARNING:**

This symbol indicates a precaution.
It gives information concerning the safety of the operator and those in the surroundings.
Read and understand these precautions thoroughly before performing the work.

Always comply with warnings and precautions so as to avoid any accidents.

This section covers information related to overall safety.

Check whether all warning labels are in place.

Additional labels can be ordered from Service Parts.

 **WARNING:**

Read the operator's manual to gain a thorough understanding of machine control operations.

 **WARNING:**

Perform any machine operations from the seating position.
Any other method may cause severe injuries.

 **WARNING:**

Only the one operator is to ride on the machine. No one else is to ride on it.

 **WARNING:**

Check the safety messages in the operator's manual before starting the engine.
Check all the warning labels on the machine.
Check that no one is within the machine's operating range.
Check the operating methods in a safe location before starting the actual work.
Understand the machine operations well, then operate in compliance with all service-related laws and regulations.
The operator's manual can be purchased at your CASE CONSTRUCTION dealer.

 **WARNING:**

Working with sloppy clothes or clothes with which safety cannot be ensured leads to damage to the machine and injury to the operator.
Always wear clothes that ensures safety.
In order to work more safely, it is recommended to wear additional safety equipment.
Helmet, safety shoes, ear protection, goggles, work clothes, and gloves

 **WARNING:**

Pay careful attention when working with the engine running.

 **WARNING:**

Check hydraulic equipment.
Work according to the procedure.
Do not change the procedure.

INTRODUCTION

 WARNING:

Check that there is no one in the surroundings before draining the pressure from hydraulic circuits during machine hydraulic cylinder inspection.

 WARNING:

Use gloves when handling high-temperature parts.

 WARNING:

Bring the lower parts or attachments in contact with the ground before inspecting or repairing them.

 WARNING:

Check that hoses and tubes are securely connected.
If there is any damage to a hose or tube, replace it.
Do not check for oil leaks by hand. Use cardboard or wood.

 WARNING:

When removing an attachment pin or other hardened pin, use a hammer that has a soft head.

 WARNING:

Wear eye protection when using a hammer to install a pin or when working with a grinder.
At this time, use goggles or eye protectors that meet standards.

 WARNING:

Park the machine in a safe location when repairing or inspecting it.

 WARNING:

Use work site protection when repairing the machine.
Check the oil, coolant, grease, and tools.
Recover materials and parts as necessary.
Pay enough attention to safety.

 WARNING:

Some of the machine's parts are extremely heavy.
Use an appropriate lifting equipment for such parts.
For weights and procedures, see the Service Manual.

 WARNING:

Exhaust gases are toxic.
Always provide good ventilation when working indoors or in any other enclosed space.

 WARNING:

If the electrolytic battery solution freezes, it may explode.

Safety rules - Ecology and the environment

Soil, air, and water quality is important for all industries and life in general. When legislation does not yet rule the treatment of some of the substances that advanced technology requires, sound judgment should govern the use and disposal of products of a chemical and petrochemical nature.

Familiarize yourself with the relative legislation applicable to your country, and make sure that you understand this legislation. Where no legislation exists, obtain information from suppliers of oils, filters, batteries, fuels, anti-freeze, cleaning agents, etc., with regard to the effect of these substances on man and nature and how to safely store, use, and dispose of these substances.

Helpful hints

- Avoid the use of cans or other inappropriate pressurized fuel delivery systems to fill tanks. Such delivery systems may cause considerable spillage.
- In general, avoid skin contact with all fuels, oils, acids, solvents, etc. Most of these products contain substances that may be harmful to your health.
- Modern oils contain additives. Do not burn contaminated fuels and or waste oils in ordinary heating systems.
- Avoid spillage when you drain fluids such as used engine coolant mixtures, engine oil, hydraulic fluid, brake fluid, etc. Do not mix drained brake fluids or fuels with lubricants. Store all drained fluids safely until you can dispose of the fluids in a proper way that complies with all local legislation and available resources.
- Do not allow coolant mixtures to get into the soil. Collect and dispose of coolant mixtures properly.
- The air-conditioning system contains gases that should not be released into the atmosphere. Consult an air-conditioning specialist or use a special extractor to recharge the system properly.
- Repair any leaks or defects in the engine cooling system or hydraulic system immediately.
- Do not increase the pressure in a pressurized circuit as this may lead to a component failure.
- Protect hoses during welding. Penetrating weld splatter may burn a hole or weaken hoses, allowing the loss of oils, coolant, etc.

Battery recycling

Batteries and electric accumulators contain several substances that can have a harmful effect on the environment if the batteries are not properly recycled after use. Improper disposal of batteries can contaminate the soil, groundwater, and waterways. CASE CONSTRUCTION strongly recommends that you return all used batteries to a CASE CONSTRUCTION dealer, who will dispose of the used batteries or recycle the used batteries properly. In some countries, this is a legal requirement.



Mandatory battery recycling

NOTE: The following requirements are mandatory in Brazil.

Batteries are made of lead plates and a sulfuric acid solution. Because batteries contain heavy metals such as lead, CONAMA Resolution 401/2008 requires you to return all used batteries to the battery dealer when you replace any batteries. Do not dispose of batteries in your household garbage.

Points of sale are obliged to:

- Accept the return of your used batteries
- Store the returned batteries in a suitable location
- Send the returned batteries to the battery manufacturer for recycling

Torque - Bolt and nut

- Tighten alternating between left and right and top and bottom so that uniform tightening force is applied.

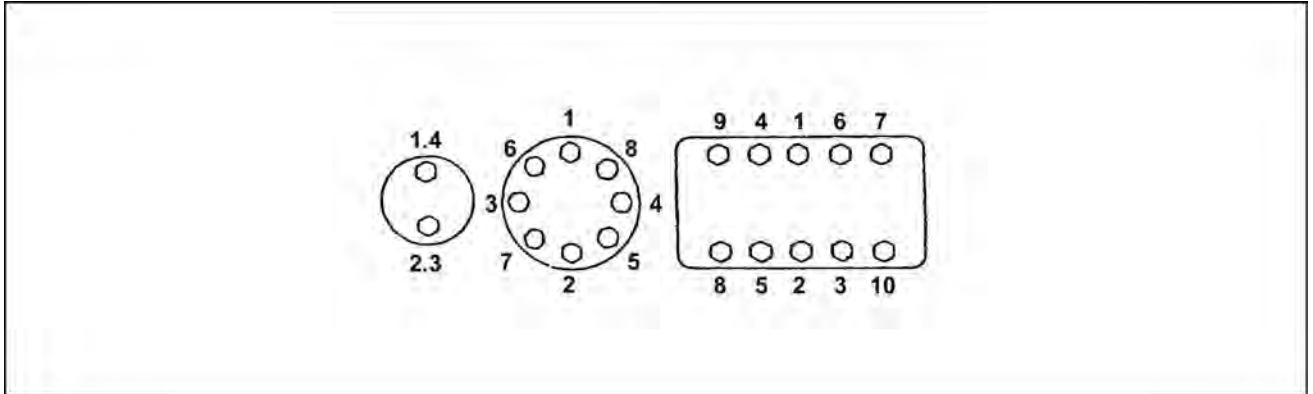

LPIL12CX00005EA 1

- If **LOCTITE®** was used on a removed bolt (there is something white sticking to the bolt when it is removed), clean the old **LOCTITE®** off with cleaning fluid, dry the bolt, then apply 2 - 3 drops of **LOCTITE®** to the thread section of the bolt.

Torque table

Bolt nominal diameter (size)		M6	M8	M10	M12	M14	M16	M18	M20
Hexagon bolt	Wrench	10 mm	13 mm	17 mm	19 mm	22 mm	24 mm	27 mm	30 mm
	Tightening torque	6.9 N·m (5.089 lb ft)	19.6 N·m (14.456 lb ft)	39.2 N·m (28.912 lb ft)	58.8 N·m (43.369 lb ft)	98.1 N·m (72.355 lb ft)	156.9 N·m (115.72 lb ft)	196.1 N·m (144.63 lb ft)	294.2 N·m (216.99 lb ft)
Hexagon socket head bolt	Wrench	5 mm	6 mm	8 mm	10 mm	12 mm	14 mm	14 mm	17 mm
	Tightening torque	8.8 N·m (6.491 lb ft)	21.6 N·m (15.931 lb ft)	42.1 N·m (31.051 lb ft)	78.5 N·m (57.899 lb ft)	117.7 N·m (86.811 lb ft)	176.5 N·m (130.18 lb ft)	245.2 N·m (180.85 lb ft)	343.2 N·m (253.13 lb ft)

Torque - Special torque setting

CX290D Crawler excavators LC Material Handling (TIER4 FINAL) - EU Market

WE

Code	Retightening location		Bolt nominal diameter	Wrench	Tightening torque
1*	Travel motor		M16	24 mm	267 – 312 N·m (196.93 – 230.12 lb ft)
2*	Drive sprocket		M16	24 mm	267 – 312 N·m (196.93 – 230.12 lb ft)
3*	Take-up roller		M16	24 mm	267 – 312 N·m (196.93 – 230.12 lb ft)
4*	Upper roller		M20	30 mm	521 – 608 N·m (384.27 – 448.44 lb ft)
5*	Lower roller		M18	27 mm	371 – 432 N·m (273.64 – 318.63 lb ft)
6*	Track guard		M18	27 mm	400 – 462 N·m (295.02 – 340.75 lb ft)
7	Shoe		M20	30 mm	250 – 350 N·m (184.39 – 258.15 lb ft) + 120°
8	Counterweight		M33	50 mm	1960 – 2156 N·m (1445.87 – 1590.18 lb ft)
9	Turntable bearing	Lower frame	M24	36 mm	784 – 914 N·m (578.25 – 674.13 lb ft)
10		Swing frame	M24	36 mm	784 – 914 N·m (578.25 – 674.13 lb ft)
11*	Swing unit		M24	36 mm	784 – 914 N·m (578.25 – 674.13 lb ft)
12*	Engine	Engine mount (front)	M16	24 mm	264.9 – 313.9 N·m (195.38 – 231.52 lb ft)
13*		Engine mount (rear)	M16	24 mm	264.9 – 313.9 N·m (195.38 – 231.52 lb ft)
14*		Front bracket	M10	17 mm	63.8 – 73.6 N·m (47.06 – 54.28 lb ft)
15*		Rear bracket	M16	24 mm	205.9 – 247.1 N·m (151.86 – 182.25 lb ft)
16	Radiator		M16	24 mm	147.2 – 176.6 N·m (108.57 – 130.25 lb ft)
17*	Hydraulic pump	Flange	M10	17 mm	63.7 – 72.6 N·m (46.98 – 53.55 lb ft)
18*		Pump	M20	17 mm hexagon socket head	367 – 496 N·m (270.69 – 365.83 lb ft)
19*	Hydraulic tank		M16	24 mm	232.4 – 276 N·m (171.41 – 203.57 lb ft)
20*	Fuel tank		M16	24 mm	232.4 – 276 N·m (171.41 – 203.57 lb ft)
21*	Urea tank		M16	24 mm	225.6 – 264.8 N·m (166.39 – 195.31 lb ft)
22*	Control valve		M16	24 mm	267 – 312 N·m (196.93 – 230.12 lb ft)
23*	Center	Swing frame	M12	19 mm	88.3 – 107 N·m (65.13 – 78.92 lb ft)
24*	Joint	Lower frame	M12	19 mm	109 – 127 N·m (80.39 – 93.67 lb ft)
25	Cab		M16	24 mm	149 – 173 N·m (109.90 – 127.60 lb ft)
26	Battery		M10	17 mm	8 – 12 N·m (5.90 – 8.85 lb ft)

NOTICE: Always apply **LOCTITE® 262™** or equivalent to the locations with mark * and tighten them with the specified torque.

INTRODUCTION

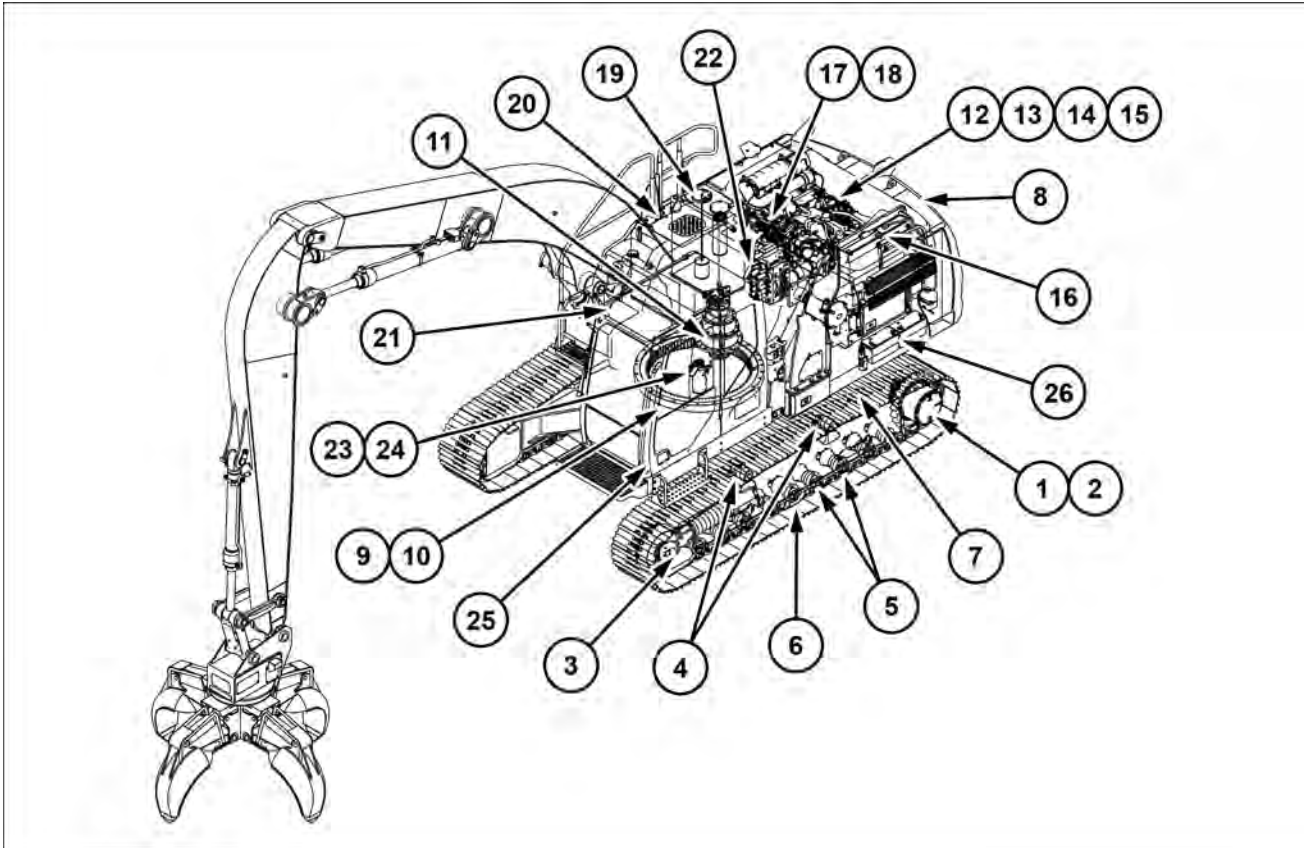

SMIL17CEX7211FB 1

INTRODUCTION

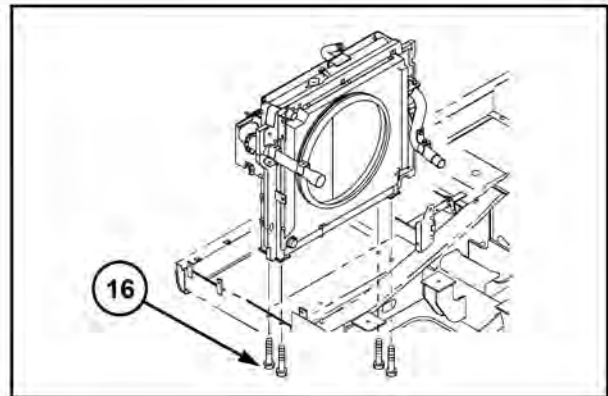
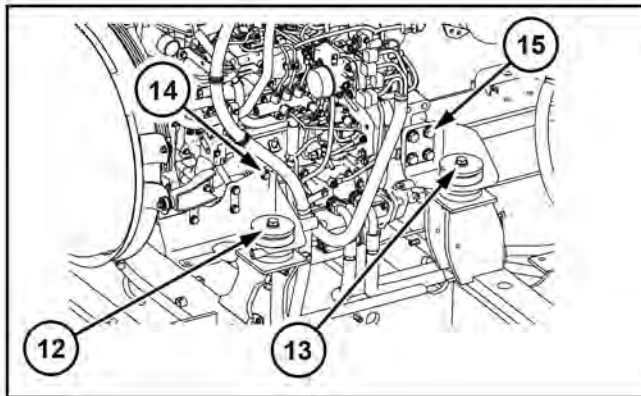
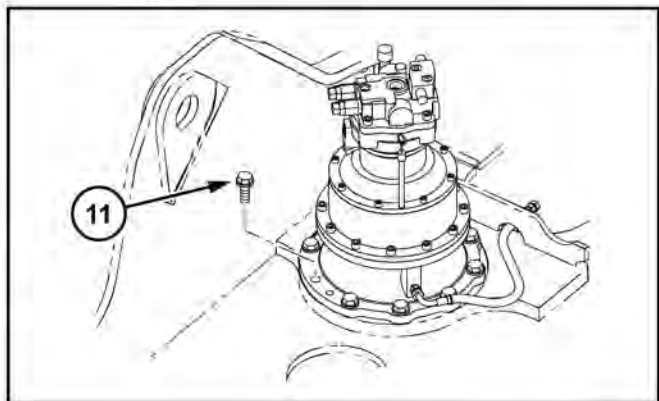
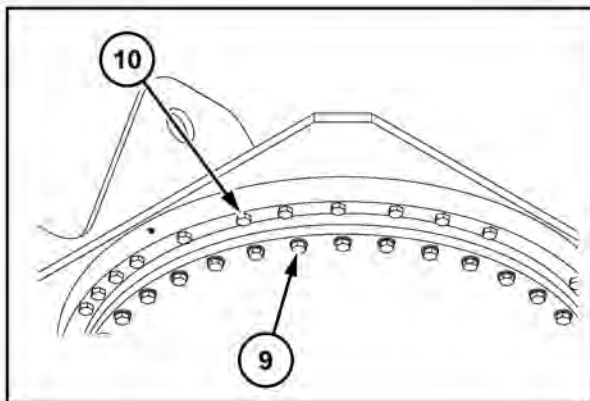
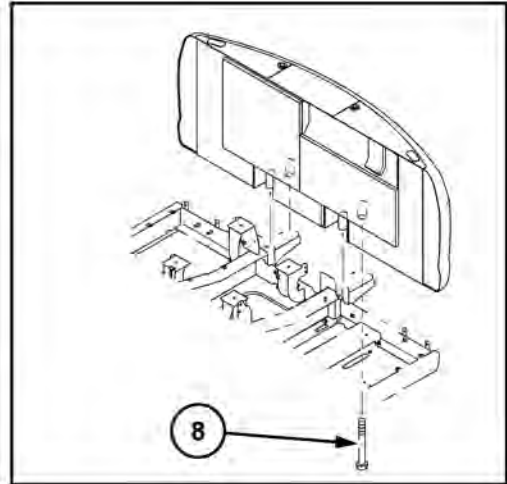
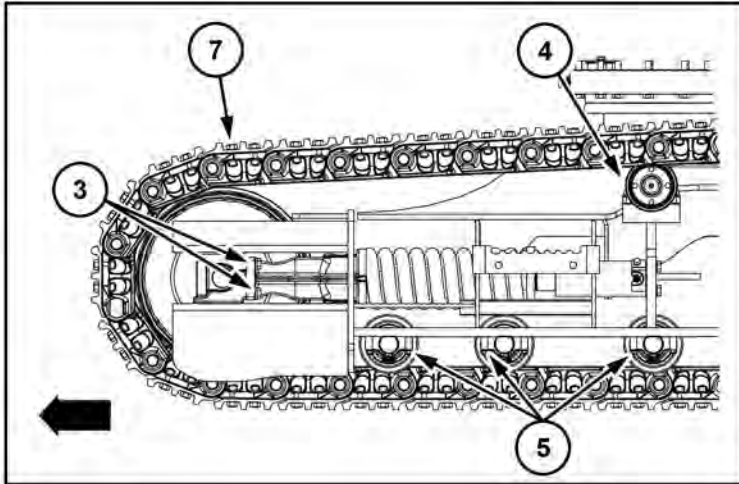
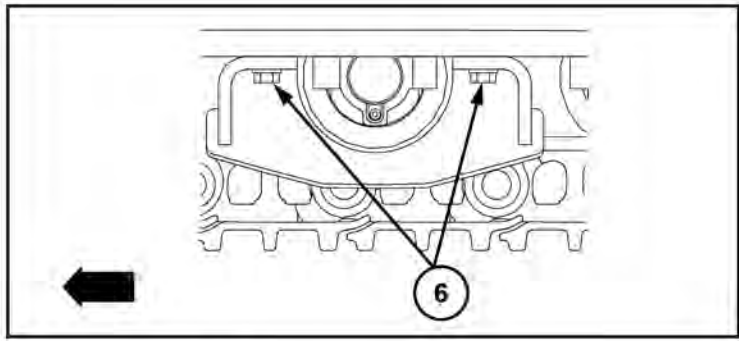
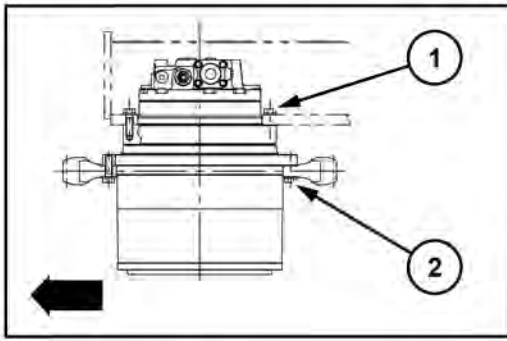

SMIL17CEX7213HB 2

INTRODUCTION

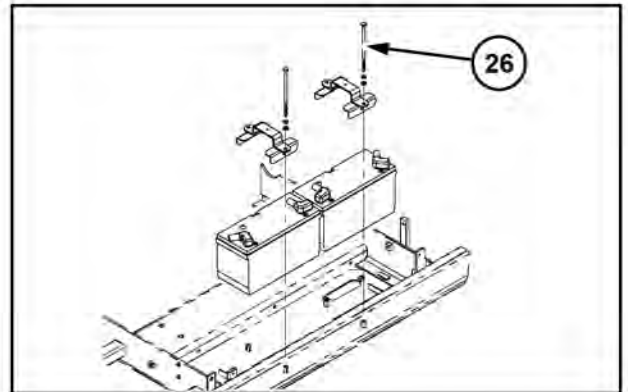
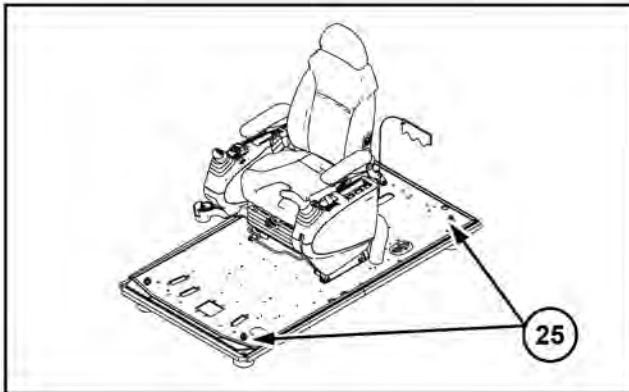
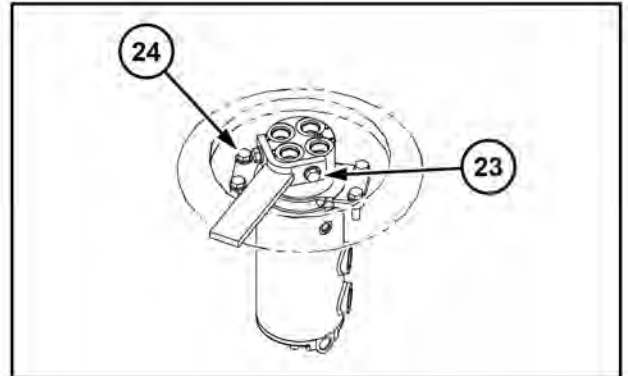
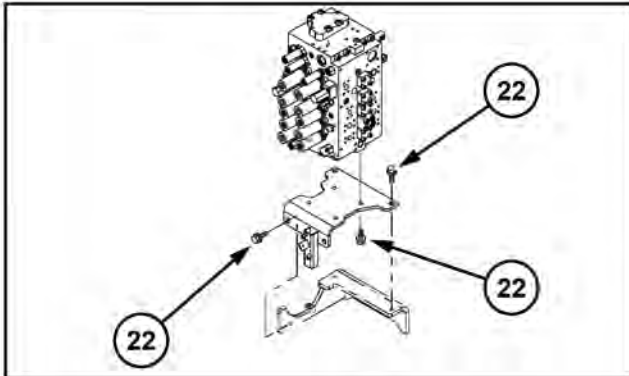
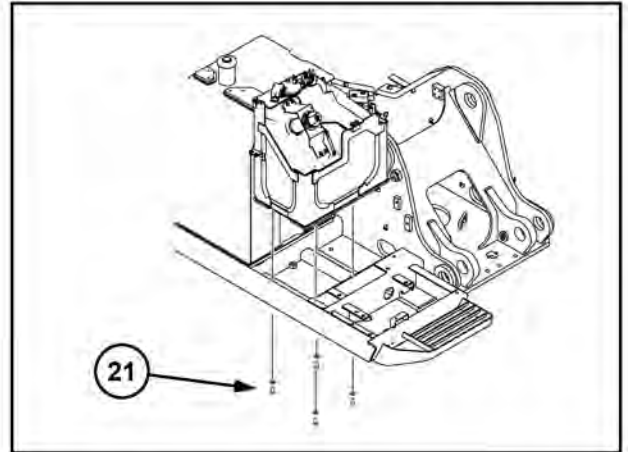
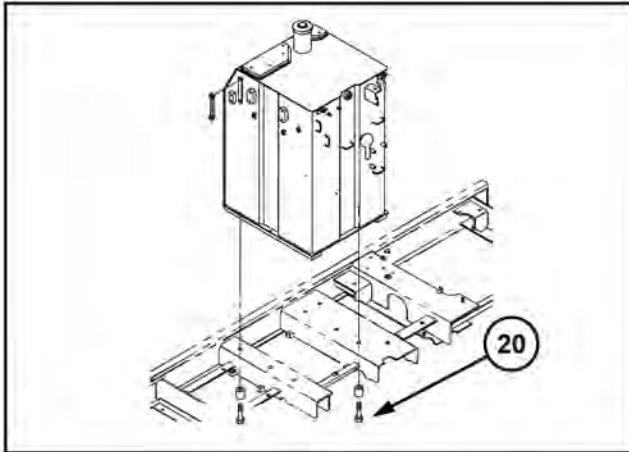
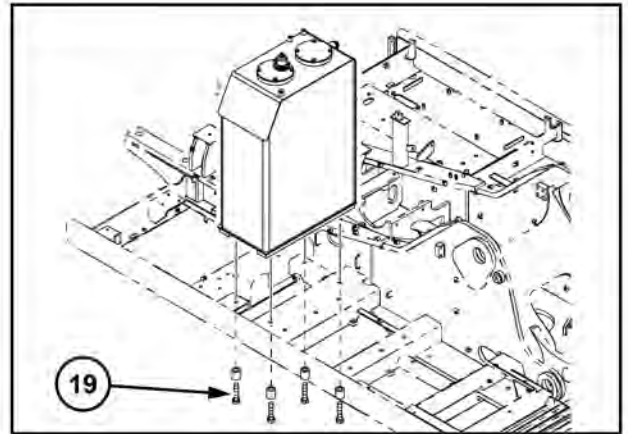
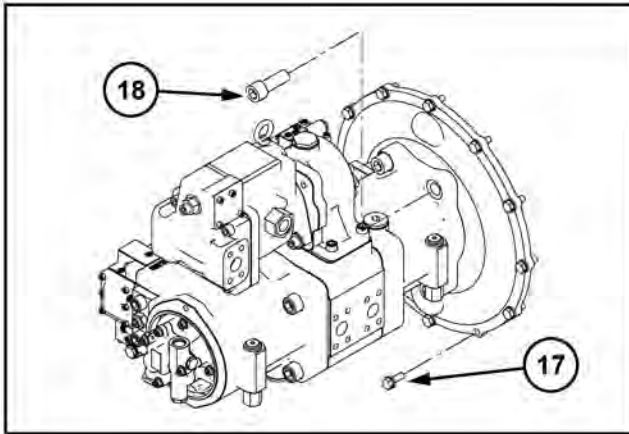

SMIL17CEX7214HB 3

Torque - Special torque setting

CX290D Crawler excavators LC Scrap Loader (TIER4 FINAL) - EU Market | WE

Code	Retightening location		Bolt nominal diameter	Wrench	Tightening torque
1*	Travel motor		M16	24 mm	267 – 312 N·m (196.93 – 230.12 lb ft)
2*	Drive sprocket		M16	24 mm	267 – 312 N·m (196.93 – 230.12 lb ft)
3*	Take-up roller		M16	24 mm	267 – 312 N·m (196.93 – 230.12 lb ft)
4*	Upper roller		M20	30 mm	521 – 608 N·m (384.27 – 448.44 lb ft)
5*	Lower roller		M18	27 mm	371 – 432 N·m (273.64 – 318.63 lb ft)
6*	Track guard		M18	27 mm	400 – 462 N·m (295.02 – 340.75 lb ft)
7	Shoe		M20	30 mm	250 – 350 N·m (184.39 – 258.15 lb ft) + 120°
8	Counterweight		M33	50 mm	1960 – 2156 N·m (1445.87 – 1590.18 lb ft)
9	Turntable bearing	Lower frame	M24	36 mm	784 – 914 N·m (578.25 – 674.13 lb ft)
10		Swing frame	M24	36 mm	784 – 914 N·m (578.25 – 674.13 lb ft)
11*	Swing unit		M24	36 mm	784 – 914 N·m (578.25 – 674.13 lb ft)
12*	Engine	Engine mount (front)	M16	24 mm	264.9 – 313.9 N·m (195.38 – 231.52 lb ft)
13*		Engine mount (rear)	M16	24 mm	264.9 – 313.9 N·m (195.38 – 231.52 lb ft)
14*		Front bracket	M10	17 mm	63.8 – 73.6 N·m (47.06 – 54.28 lb ft)
15*		Rear bracket	M16	24 mm	205.9 – 247.1 N·m (151.86 – 182.25 lb ft)
16	Radiator		M16	24 mm	147.2 – 176.6 N·m (108.57 – 130.25 lb ft)
17*	Hydraulic pump	Flange	M10	17 mm	63.7 – 72.6 N·m (46.98 – 53.55 lb ft)
18*		Pump	M20	17 mm hexagon socket head	367 – 496 N·m (270.69 – 365.83 lb ft)
19*	Hydraulic tank		M16	24 mm	232.4 – 276 N·m (171.41 – 203.57 lb ft)
20*	Fuel tank		M16	24 mm	232.4 – 276 N·m (171.41 – 203.57 lb ft)
21*	Urea tank		M16	24 mm	225.6 – 264.8 N·m (166.39 – 195.31 lb ft)
22*	Control valve		M16	24 mm	267 – 312 N·m (196.93 – 230.12 lb ft)
23*	Center Joint	Swing frame	M12	19 mm	88.3 – 107 N·m (65.13 – 78.92 lb ft)
24*		Lower frame	M12	19 mm	109 – 127 N·m (80.39 – 93.67 lb ft)
25	Cab		M16	24 mm	149 – 173 N·m (109.90 – 127.60 lb ft)
26	Battery		M10	17 mm	8 – 12 N·m (5.90 – 8.85 lb ft)

NOTICE: Always apply **LOCTITE® 262™** or equivalent to the locations with mark * and tighten them with the specified torque.